

Meets/Exceeds ASTM E-84 Class A
Fire Rating and ASTM F2440-11
Requirements for Impact Absorption

14 oz. Indoor Vinyl, Class A Fire Rated (ASTM E-84),
Various Standard Colors Available

1" Vinyl Wrapped Attachment Lips
Top and Bottom

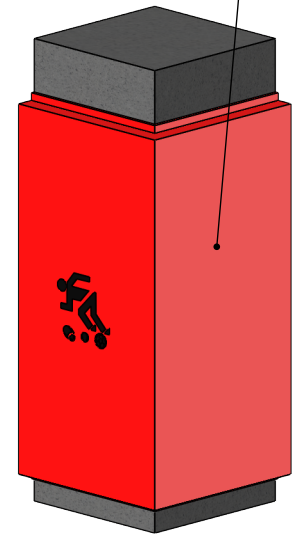
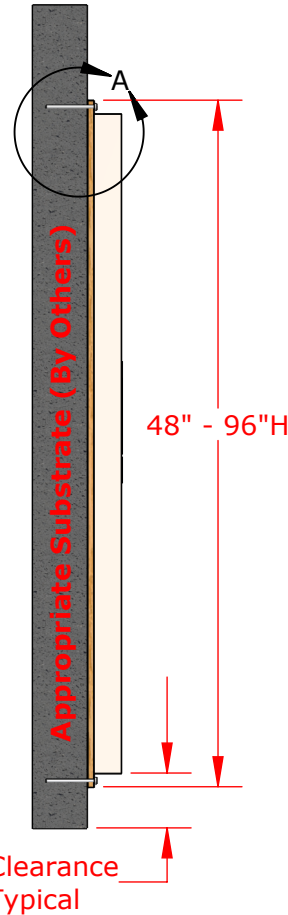
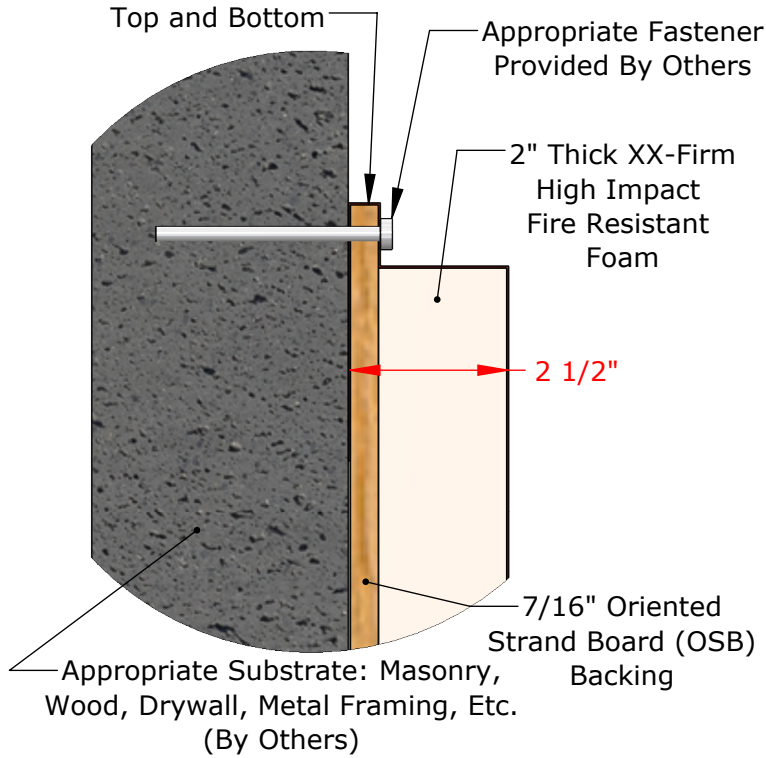

Squared Column Pad

2 Sided Pad

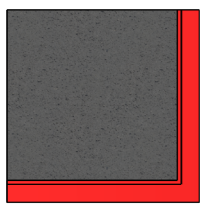

3 Sided Pad

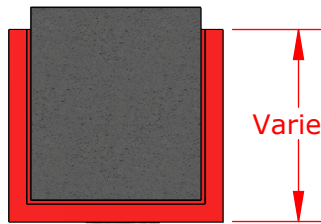

Varies

Varies

Varies

Optional Custom Digitally Printed Lettering And/Or Graphics Available

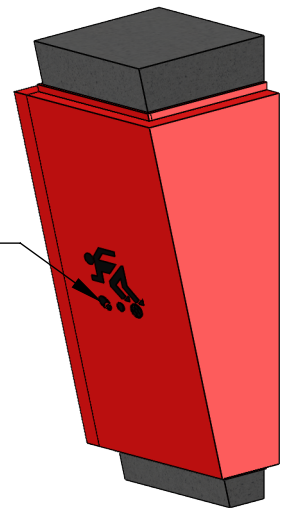

Tapered Column Pad

Part Numbers	Description
COP2XFR	2 Sided, Squared
COP2TXFR	2 Sided, Tapered
COP3XFR	3 Sided, Squared
COP3TXFR	3 Sided, Tapered

Final Layout and/or Graphic Rendering to be Completed upon Verification of Field Measurements

PROPRIETARY AND CONFIDENTIAL

THE INFORMATION CONTAINED IN THIS DRAWING IS THE SOLE PROPERTY OF SPORTSFIELD SPECIALTIES INC. ANY REPRODUCTION IN PART OR AS A WHOLE WITHOUT THE WRITTEN PERMISSION OF SPORTSFIELD SPECIALTIES INC. IS PROHIBITED.

COPXFR ProSafe Premium Fire Rated Column Pad Attachment Lip Top and Bottom

Not To Scale

Sportsfield Specialties Inc 08112020