



1-888-975-3343

**Install Instructions
High Jump Standards**

Product No.	Product Description
HJS0208	High Jump Standards, 2' - 8' Height Range

High Jump Standards Assembly..... ID-00029 Sheet 1
High Jump Standards Operation and Adjustment ID-00029 Sheet 2

Tools Required: 7/16" Socket, 9/16" Socket, 9/16" Wrench

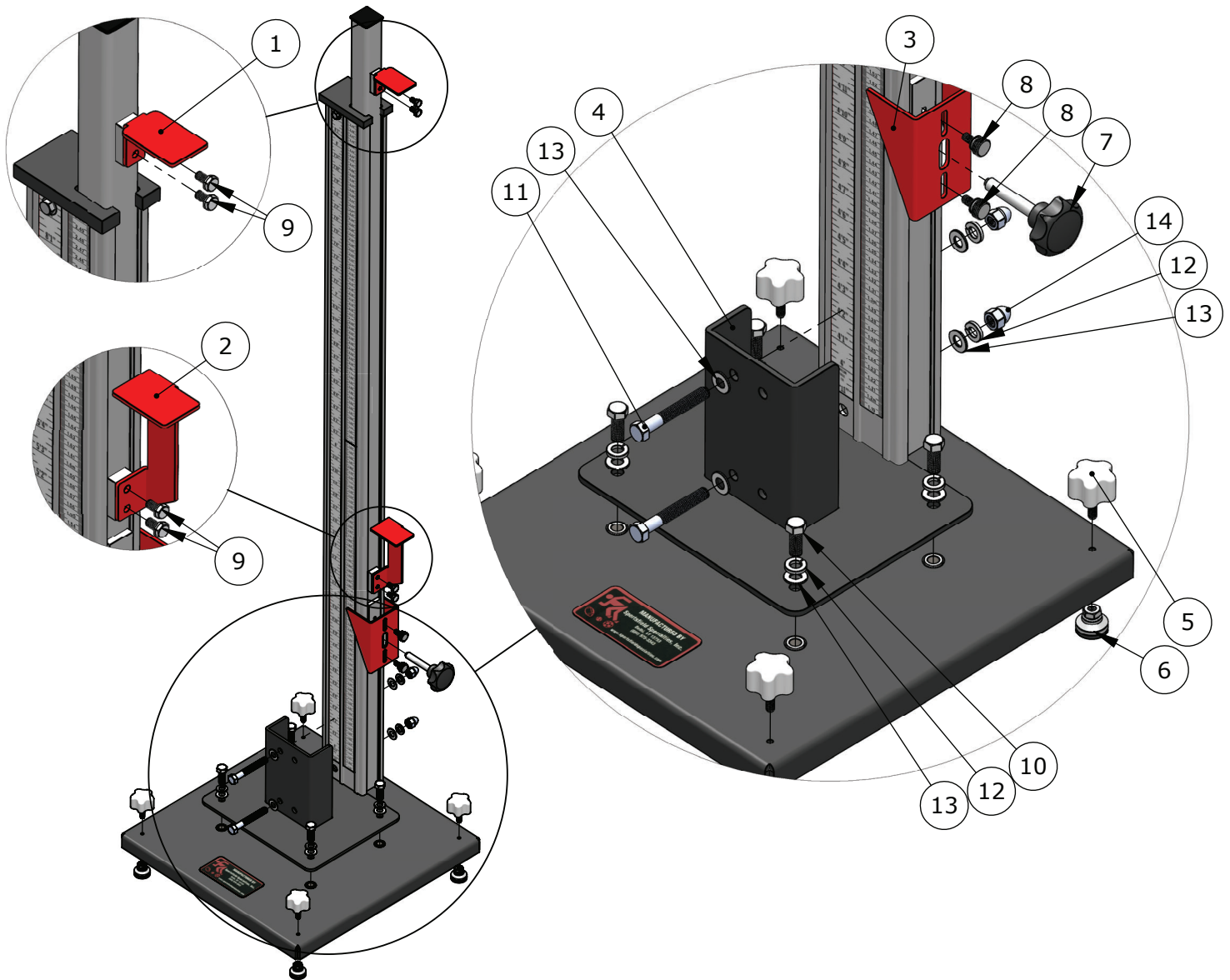

Left Side Shown Above, Mirror Assembly For Right Side

ITEM NO.	QTY.	DESCRIPTION	SAP PART NUMBER
1	2	Bar Rest, High Jump Hardware Kit	Undefined
2	2	Lower Bar Rest, High Jump Hardware Kit	Undefined
3	2	Measurement Gauge, High Jump Hardware Kit	Undefined
4	2	Stub, High Jump Hardware Kit	Undefined
5	8	Plastic Star Knob - 1/4-20 x 3/4" Steel Threaded Stud	PURCHP-0722
6	8	Swivel Leveling Mount; 1/4-20 Threaded Hole	PURCHP-0743
7	2	Plastic Star Knob, M10 x 1.5mm, SS, 55mm Stud Length	PURCHP-0918
8	4	1/4-20 x 1/2", Flared Collar Knurled Head Thumb Screw, SS	104-SCREWS-0034
9	8	1/4-20 x .50" hex head bolt, 304 SS	101-HHC-0016
10	8	3/8-16 x 1.00" Hex Head Bolt, 304 SS	101-HHC-0033
11	4	3/8-16 x 2.75" Hex Head Bolt, 304 SS	101-HHC-0065
12	12	3/8-16 S. S. Lock Washer	110-SLW-0006
13	16	3/8 S.S. FLAT WASHER	110-FLW-0005
14	4	3/8-16 S.S. High Crown Acorn Nut	107-HXN-0015

TITLE:

High Jump Standards Assembly

DWG NO:

ID-00029

SHEET 1 OF 2

Operation/Adjustment Instructions

Vertical Adjustment - To raise or lower the Bar Supports, loosen the clamping knob, left/lower the riser assembly until at desired height, and tighten. Note that overtightening can cause damage to knob threads.

Leveling - Adjust the (4) leveling knobs on the base until upright is properly leveled.

Measurement Calibration - Loosen the (2) thumb screws on the Measurement Gauge and adjust vertically until the aligned dimension matches the measured dimension.

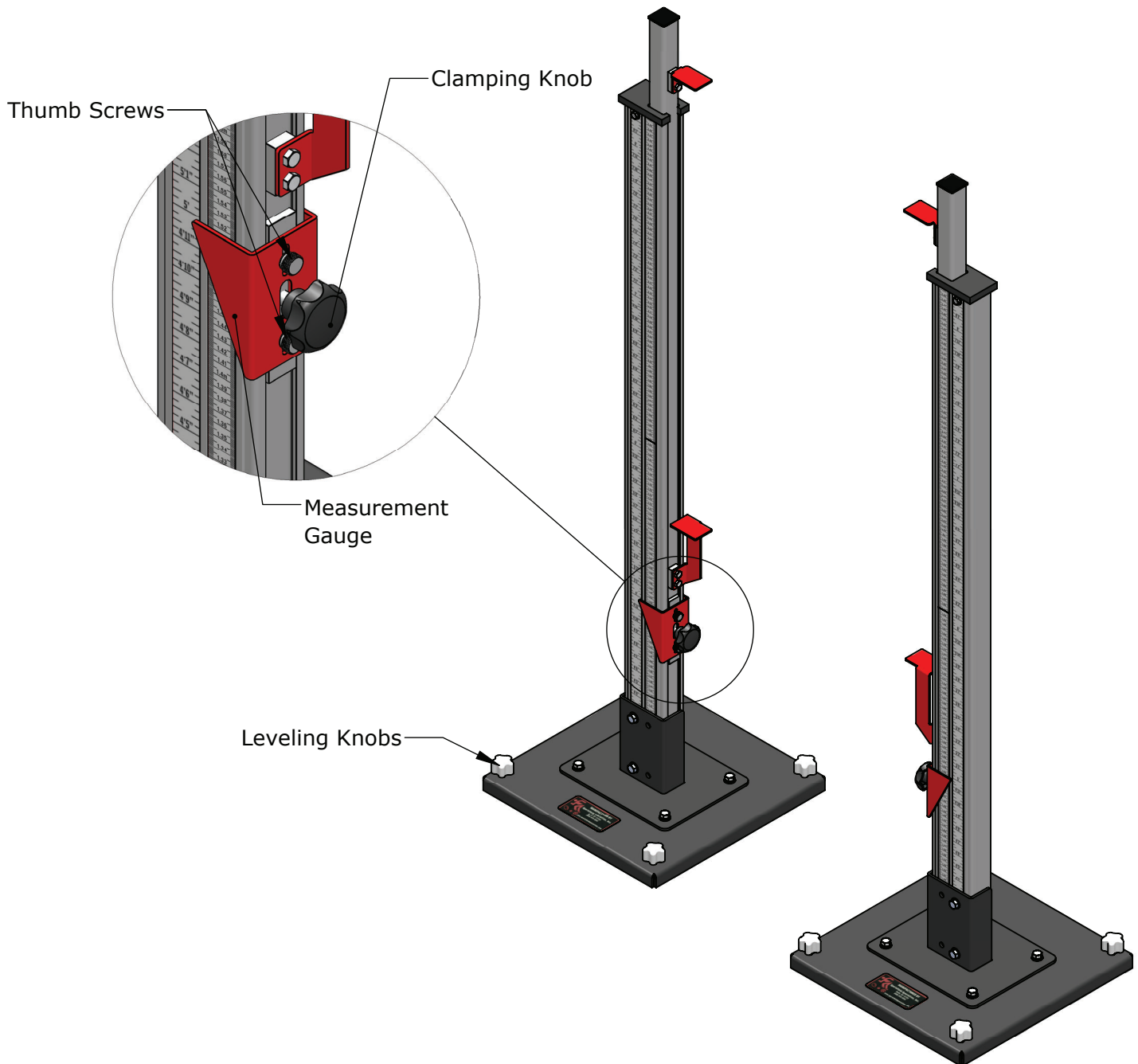

TITLE:

High Jump Standards
Operation/Adjustment

DWG NO:

ID-00029

SHEET 2 OF 2