



**1-888-975-3343**

## Install Instructions

### Two Tier Polyboard Bench

<b>Product No.</b>	<b>Product Description</b>
PTBTT8	Two Tier Polyboard Bench, 8'L
PTBTT10	Two Tier Polyboard Bench, 10'L
PTBTT12	Two Tier Polyboard Bench, 12'L
PTBTT15	Two Tier Polyboard Bench, 15'L

Bench to Bench Assembly..... ID-00165

Anchoring Assembly..... ID-00166

Use numbered stickers to identify mating bench ends

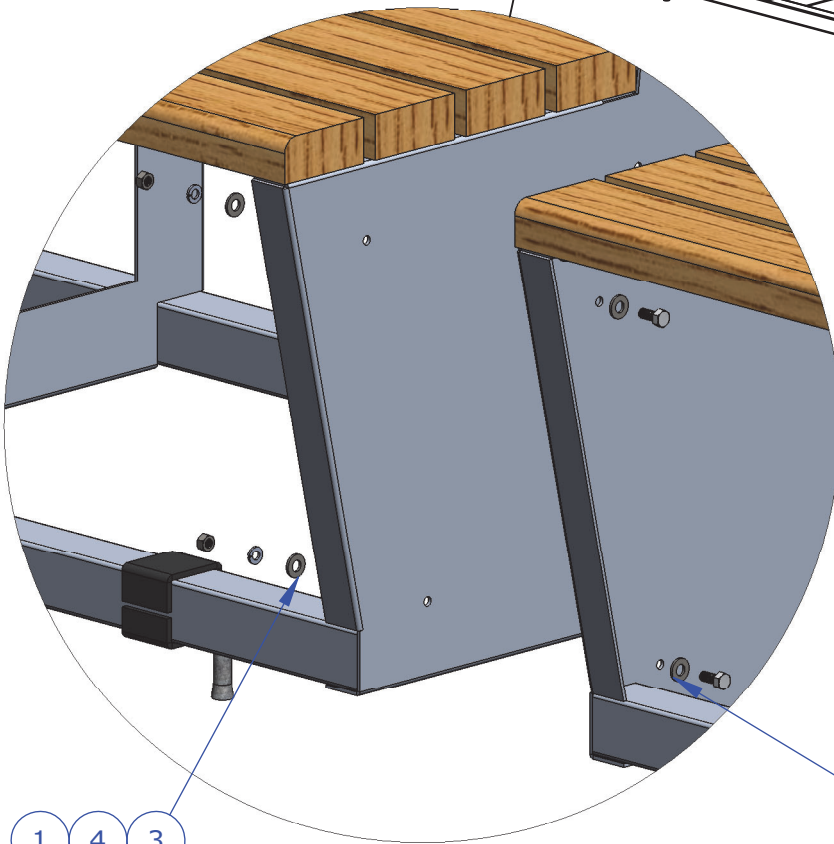
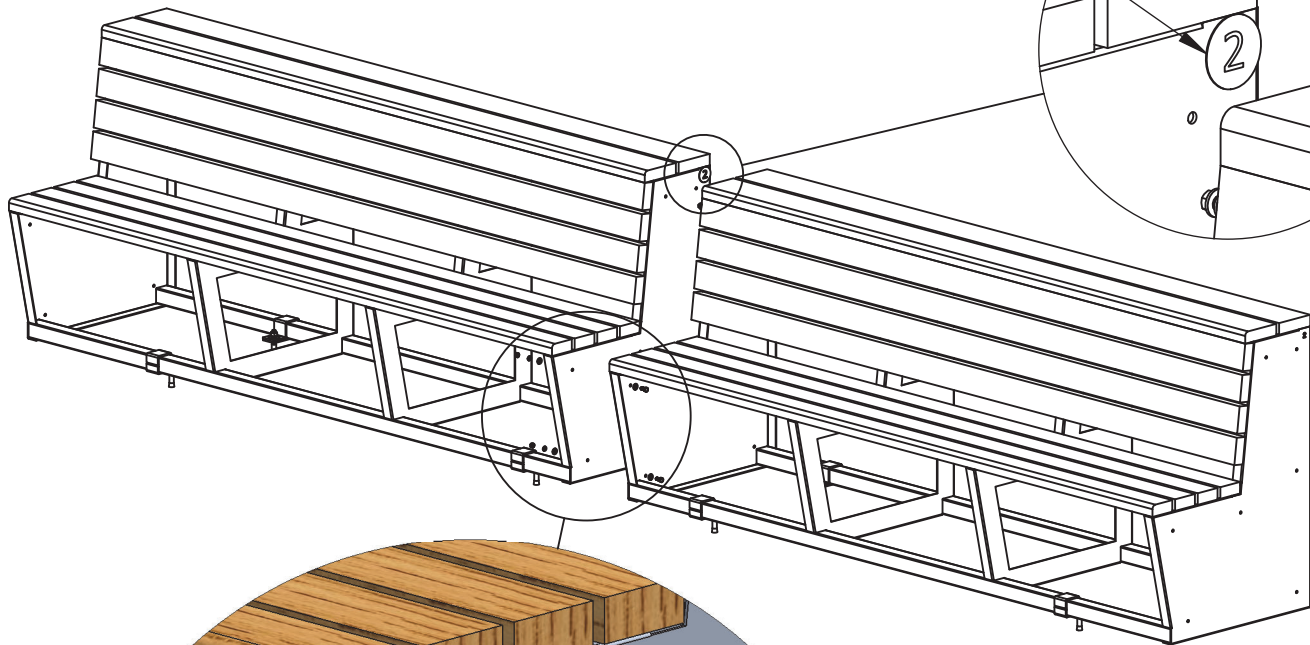
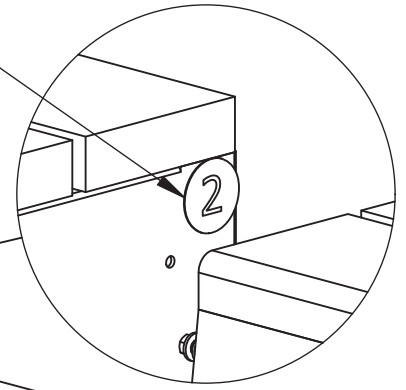

Lay out bench sections according to overall bench run. Bolt the mating ends together at all hole locations using shown connection hardware.

\*Qtys shown are per connection

ITEM NO.	QTY.*	SAP Part Number	DESCRIPTION
1	7	101-HHC-0044	5/16-18 x .75" Hex Head Bolt, SS
2	7	107-HXN-0023	5/16-18 S.S. Hex Nut
3	14	110-FLW-0007	5/16 S.S. FLAT WASHER
4	7	110-SLW-0007	5/16 S.S. LOCK WASHER

TITLE:

Bench to Bench Assembly

DWG NO:

ID-00165

SHEET 1 OF 1

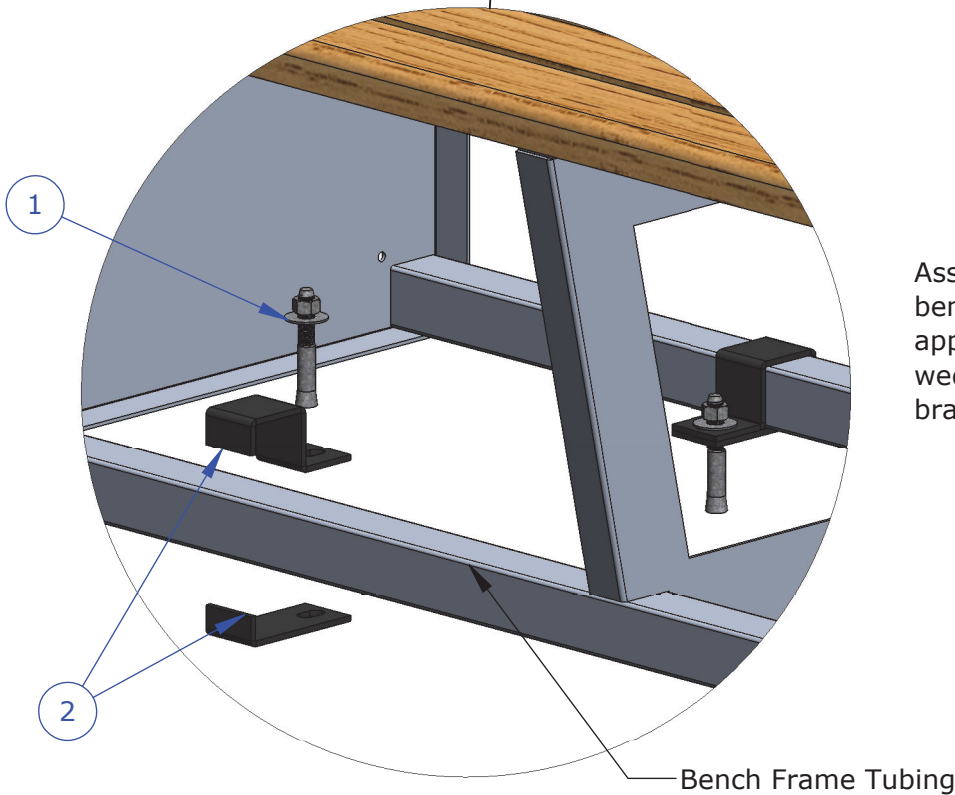
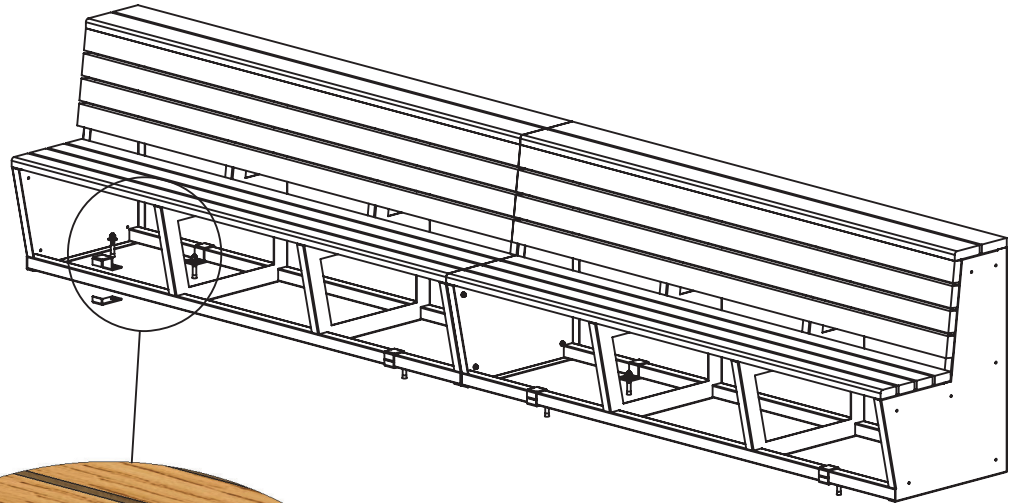
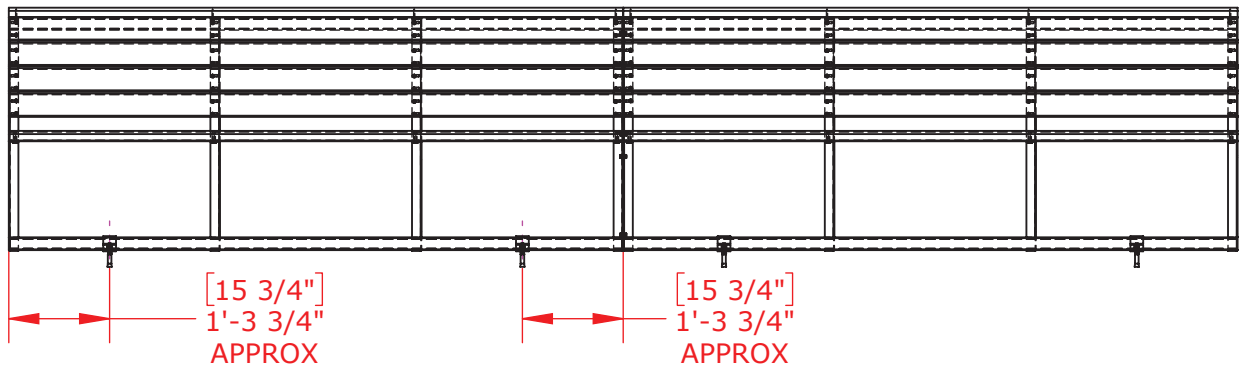

Assemble anchoring brackets around bench frame tubing at given approximate locations. Install (1) wedge anchor per set of anchoring brackets.

\*Qtys shown are per individual bench section

ITEM NO.	QTY.*	SAP Part Number	DESCRIPTION
1	4	PURCHP-0274	1/2In. dia. x 3-3/4In. L Galvanized Wedge Anchor
2	4	E-0015-S007	Anchoring Bracket Set, Team Benches, Two-Tier, Painted Black

TITLE: <b>Anchoring Assembly</b>	DWG NO: <b>ID-00166</b>
	SHEET 1 OF 1