



1-888-975-3343

Install Instructions

Pole to Pole Tension Netting with Integrated Wall Pad Backstop

Product No.	Product Description
TNPP36WPB	Netting System with Integrated Wall Pad Backstop, #36 Nylon
TNPPUCWPB	Netting System with Integrated Wall Pad Backstop, UltraCross

System Overview.....	ID-00106
Ground Sleeve and Pole Installation.....	ID-00107
Splice Pole Assembly.....	ID-00447
Rail Structure Attachment.....	ID-00108
Heat Shrink Tubing Application.....	ID-00145
Cable Attachment.....	ID-00110
Netting Attachment.....	ID-00254
Z-Clip Attachment.....	ID-00111
Pad Attachment.....	ID-00157
Backer Board Attachment.....	ID-00109

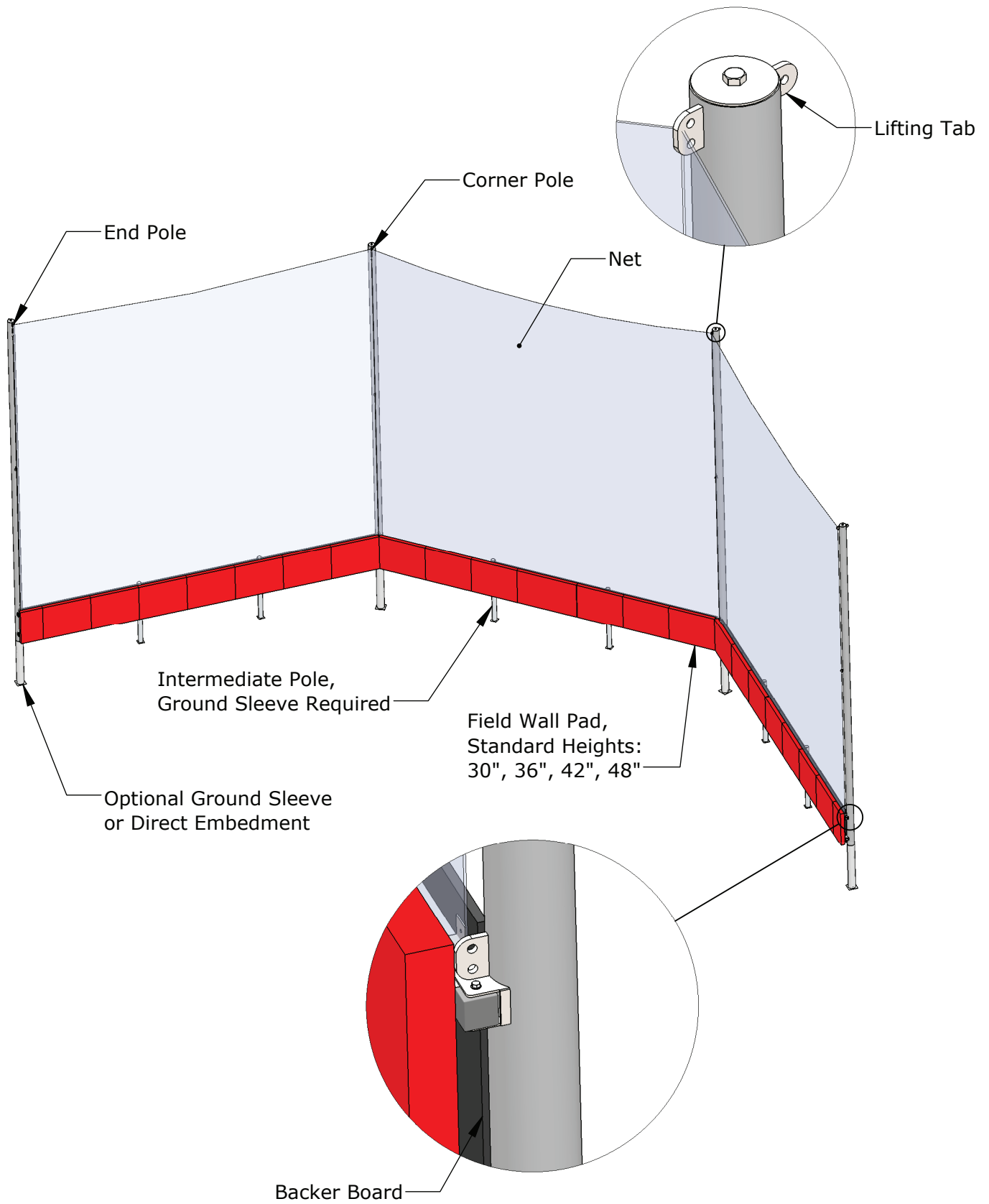

Image not to scale and may differ from system purchased

TITLE:

System Overview

DWG NO:

ID-00106

SHEET 1 OF 1

Marking Pole/Sleeve Locations

Step 1

Use the provided system pole layout to mark the locations of the corner poles, end poles, and intermediate pole ground sleeves on the field. Be sure to match the center distance to the desired system. Refer to design drawings, project specifications and/or local building codes for exact foundation dimensions, as local soil conditions will vary.

Step 2

Excavate holes for foundations and set the concrete forms.

Step 3

Prior to installing the ground sleeves, remove anti-rotation bolts at the bottom of the sleeve if present.

FAILURE TO REMOVE BOLTS WILL MAKE INSTALLATION DIFFICULT. THEY ARE NOT USED IN THIS ASSEMBLY.

Intermediate Pole Installation

Step 1

Center the ground sleeve in the form and secure it in a plum and level position. The top of the ground sleeve should be set level with finish grade.

Step 2

Pour concrete foundation to the top of the sleeve. Allow concrete to adequately cure.

Step 3

Caulk all around the top of the ground sleeve, using backer rod where needed to prevent the caulk from falling into the ground sleeve.

Step 4

Lower poles into sleeves. 4" OD intermediate poles may be placed by hand.

Corner Pole and End Pole Installation

Step 1

Use the tabs at the top of the corner poles and end poles to lift the pole into position. The lifting tab will be a single hole tab on the opposite side of the pole from the double hole tab (Detail C). Lift from both tabs so that pole is plum when placing, and center the pole in the form.

Step 2

Lower pole into ground sleeve or concrete form. Position pole such that the tabs face outwards towards the field in the appropriate orientation. The lifting tab faces away from the field.

Step 3

Repeat for all poles. Ensure that all poles can be rotated in their respective ground sleeves.

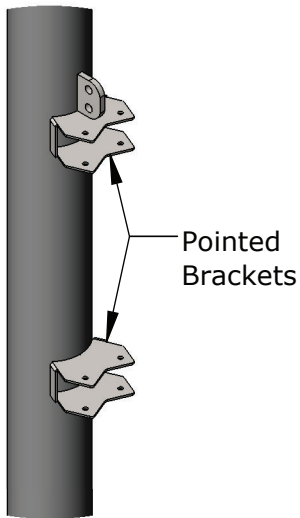

Detail A
Corner Pole

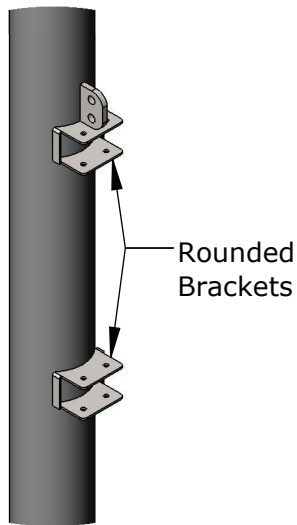

Detail B
End Pole

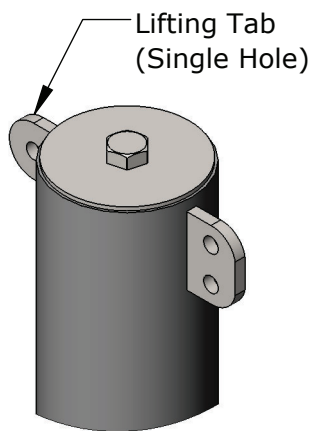

Detail C
Pole Tabs

TITLE:

Ground Sleeve and Pole Installation

DWG NO:

ID-00107

SHEET 1 OF 1

NOTE : Only applicable to systems with splice poles

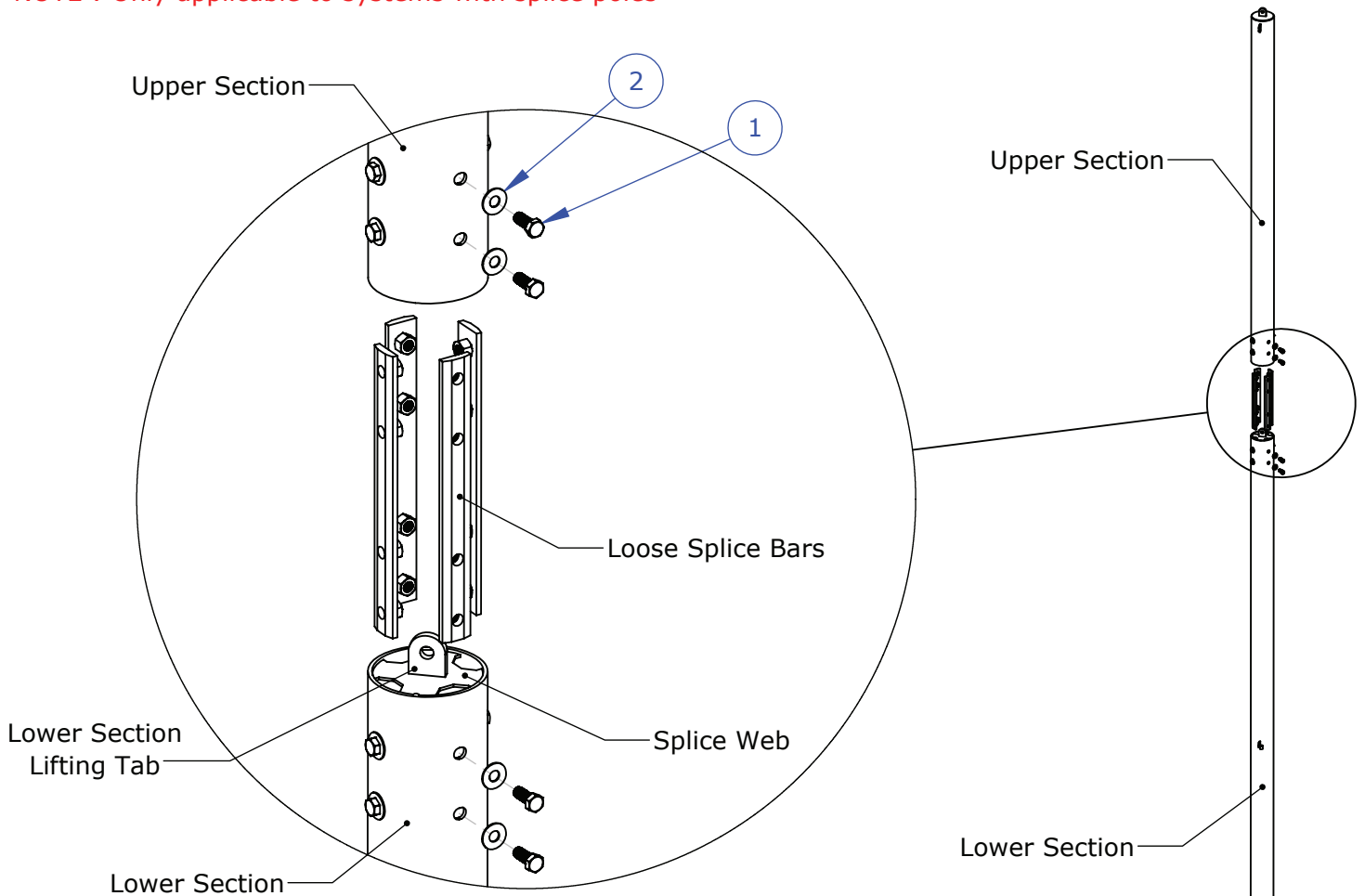

Step 1

Slide Loose Splice Bars into Lower Section of pipe, through voids in the Splice Web. Start to thread Lower Section bolts into the Splice Bar nuts for all (4) Splice Bars.

Step 2

With Splice Bars loosely held in the Lower Section, slide the Upper Section of pipe over the protruding Splice Bars. With holes in Upper Section pipe aligned with the nuts in the Splice Bars, loosely install bolts through the Upper Section and into the Splice Bar nuts.

Step 3

With all bolts loosely threaded into the Splice Bars, begin to snug all bolts alternating sides of the pole assembly, Upper and Lower Sections. With all bolts snug tight, the pole assembly is complete.

ITEM NO.	QTY	DESCRIPTION
1	16	ASTM A325 Galvanized Hex Bolt
2	16	ASTM F436 Hardened Galvanized Flat Washer

TITLE: Splice Pole Assembly - Loose Splice Bars	DWG NO: ID-00447
	SHEET 1 OF 1

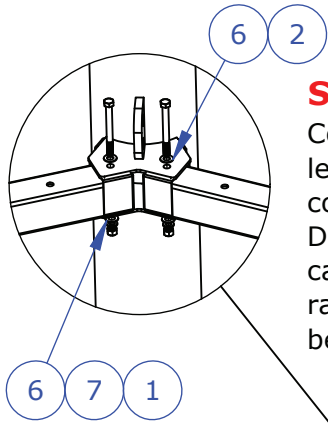

Step 1

Connect upper and lower rail lengths at corner poles using connection hardware shown. Drill through the rail and end cap to insert hardware. Cut rails to length per diagram below.

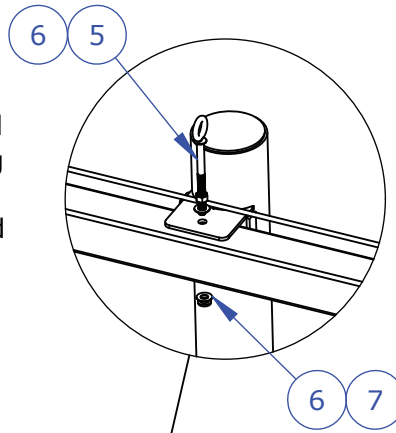

Step 2

Connect upper and lower rail lengths at intermediate poles using connection hardware shown. Drill through the rail to insert hardware.

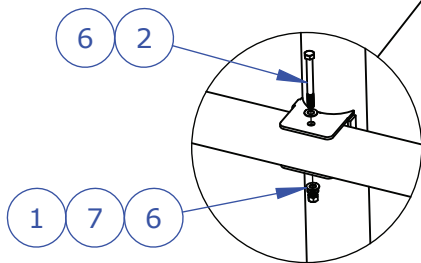
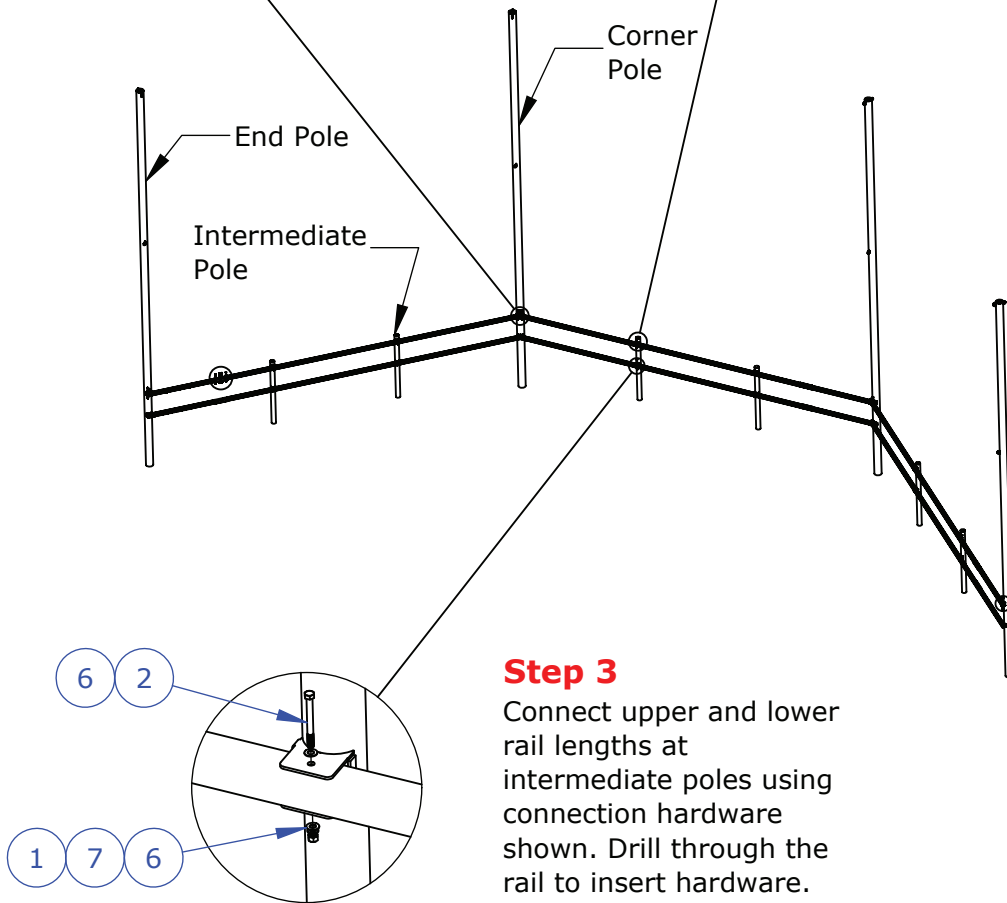

Step 3

Connect upper and lower rail lengths at intermediate poles using connection hardware shown. Drill through the rail to insert hardware.

ITEM NO.	SAP Part Number	DESCRIPTION
1	108-HXN-0004	3/8-16 GALVANIZED STEEL HEX NUT
2	102-HHC-0041	3/8-16 x 3.75" Hex Head Bolt, Galvanized
5	102-EYE-0012	3/8" x 4 1/2" Galvanized Shoulder Eye Bolt w/Hex Nut, 4.500" Shank Length, 2 1/2" Threaded Length, 3/4" I.D. Eye, 1 3/8" O.D. Eye
6	111-FLW-0004	3/8" Galvanized Steel Flat Washer
7	111-SLW-0004	3/8 Galvanized Lock Washer

TITLE:
Rail Structure Attachment

DWG NO:
ID-00108

SHEET 1 OF 2

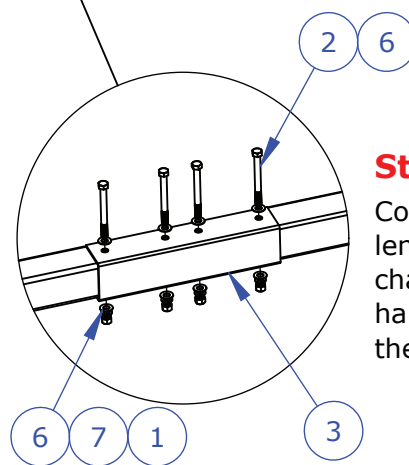
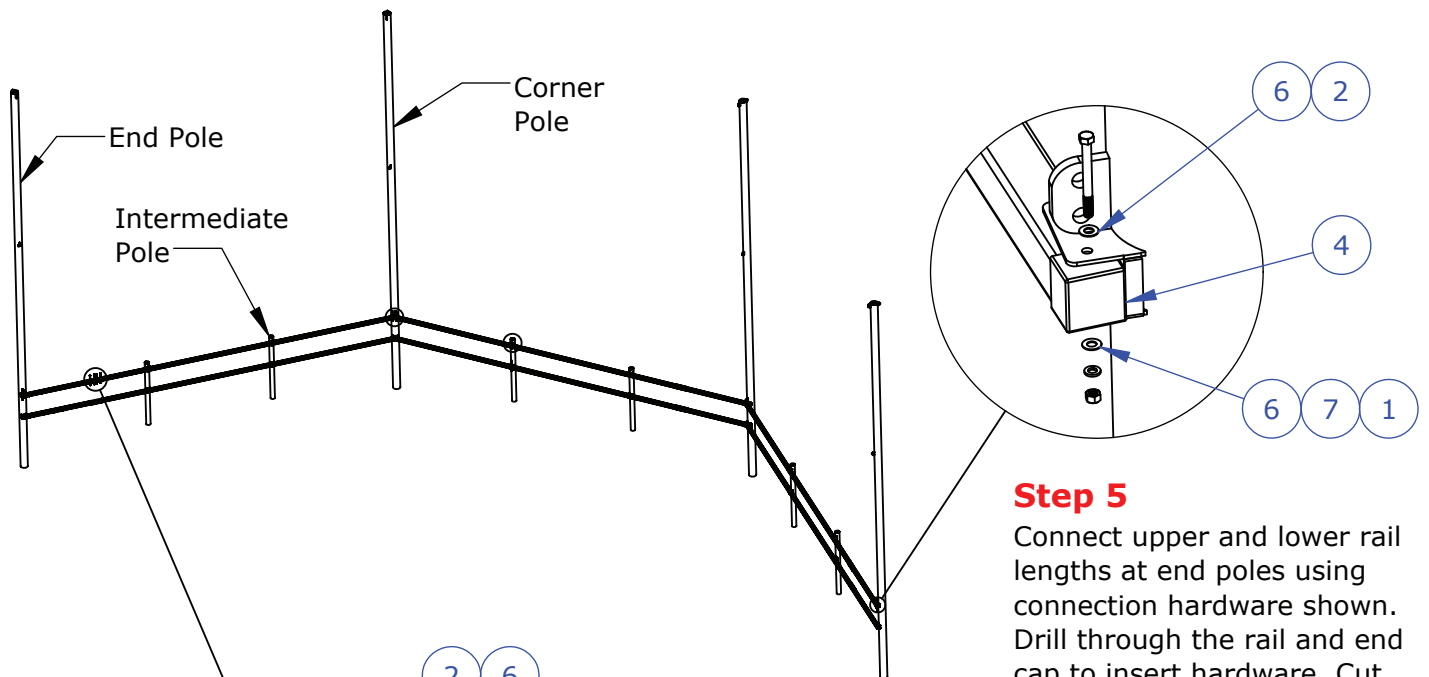

Step 4
 Connect upper and lower rail lengths at joint locations using channel and connection hardware shown. Drill through the rails to insert hardware.

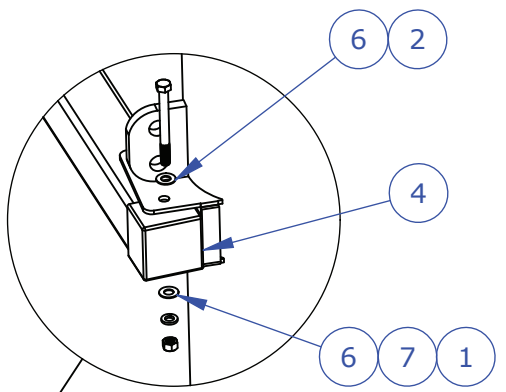

Step 5
 Connect upper and lower rail lengths at end poles using connection hardware shown. Drill through the rail and end cap to insert hardware. Cut rails to length per diagram below. It is recommended rails be set at the outside of the end (terminating) poles.

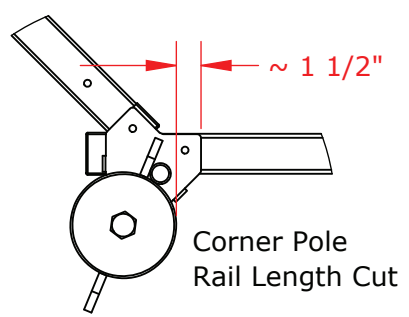

Refer to "Rail Layout" attachment for structural configuration. Note that both upper and lower Rail Lengths will come in different lengths (288", 180", 108", or 54"). Quantities of each will vary by project.

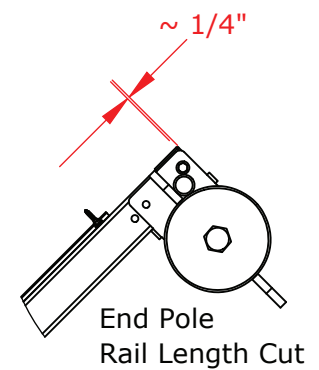

ITEM NO.	SAP Part Number	DESCRIPTION
1	108-HXN-0004	3/8-16 GALVANIZED STEEL HEX NUT
2	102-HHC-0041	3/8-16 x 3.75" Hex Head Bolt, Galvanized
3	E-1000-0051	Channel, Steel, 2.250" IDH x 2.560" IDW x 12" Long, (4) 0.438" Holes
4	PURCHP-0779	Pliable Vinyl Square Black Cap, 2-1/2" Square, 2" Inside Height
6	111-FLW-0004	3/8" Galvanized Steel Flat Washer
7	111-SLW-0004	3/8" Galvanized Lock Washer

TITLE:
Rail Structure Attachment

DWG NO:
ID-00108

SHEET 2 OF 2

Heat shrink tubing is provided at turnbuckle locations to prevent paint damage on poles and/or netting tears in high winds

Step 1

Slide the heat shrink tubing over the turnbuckle **PRIOR** to completing any cable assembly.

Step 2

After all cables are tensioned, center the heat shrink tubing over the turnbuckle.

Step 3

Using a heat gun or suitable heat source, evenly apply heat over the entire length of tubing.

Step 4

Trim any excess length of heat shrink tubing beyond the end of the turnbuckle.

CAUTION: Avoid overheating the heat shrink tubing or it may become brittle or charred.

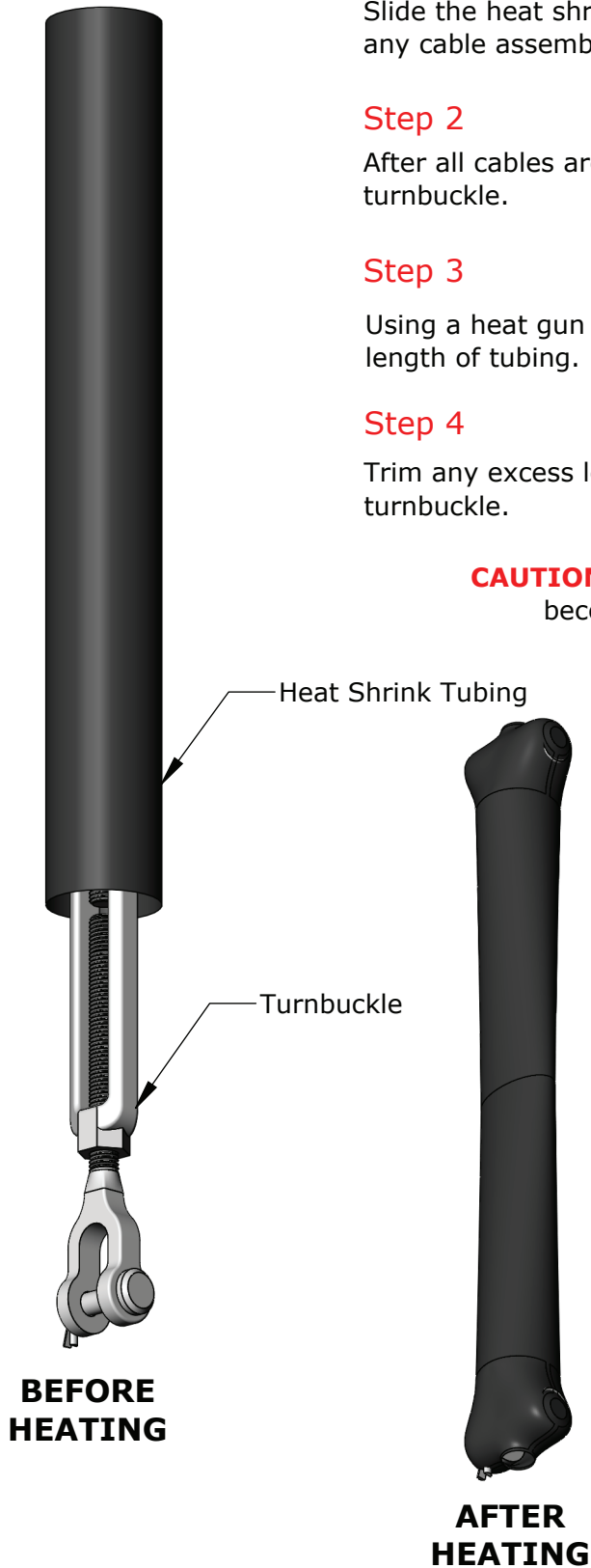

Turnbuckle Size	Heat Shrink Tubing Required
3/8" Turnbuckle	PURCHP-0884: 1-1/2" OD Tubing
1/2" Turnbuckle	PURCHP-0885: 2" OD Tubing

TITLE:
Heat Shrink Tubing Application

DWG NO:
ID-00145
SHEET 1 OF 1

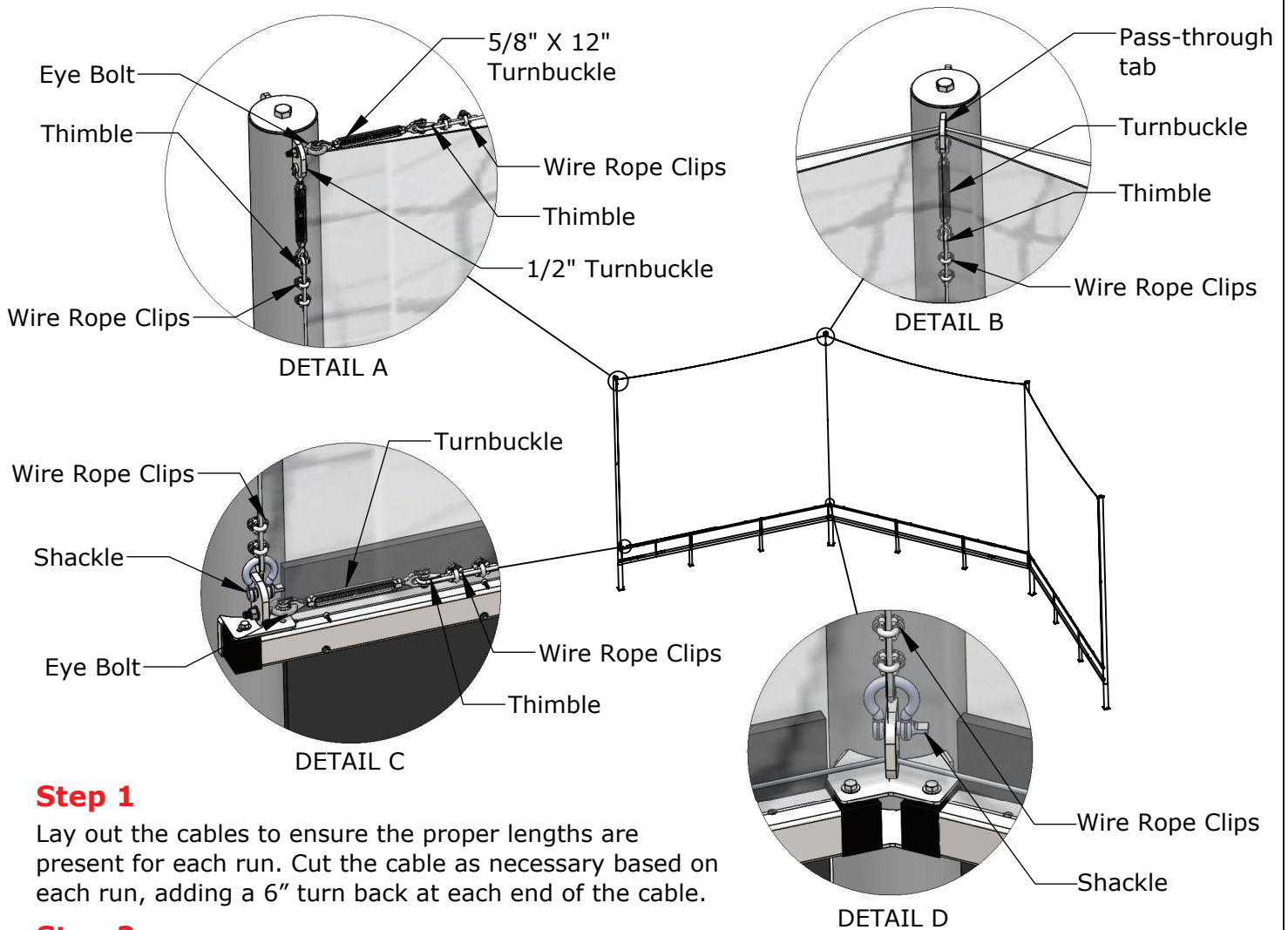

Step 1

Lay out the cables to ensure the proper lengths are present for each run. Cut the cable as necessary based on each run, adding a 6" turn back at each end of the cable.

Step 2

Start the top horizontal tension cables (5/16" DIA) by assembling a 5/8" x 12" turnbuckle to an eye bolt at one end (See Detail A). The wire will pass through the poles at which the cable run does not terminate (See Detail B). At the poles where the cable run terminates, attach the cable with turn back and rope clips directly to the eye bolt at opposite end (See Detail C).

NOTE: Listed cable sizes are standard. If your system has cables that differ in size, use the larger cable at the top of the system and the smaller cable as the bottom horizontal cable.

Step 3

The horizontal cables can be finished with the bottom (1/4" DIA) cable. This cable is assembled the same way as the tensioned cables. Start the cable by attaching to an eye bolt at one end (See Detail C). The cable will pass through the galvanized eye bolts located at the intermediate poles, then through the poles at which the cable run does not terminate. At the end pole where the cable run terminates, attach the cable with turn back and rope clips directly to the eye bolt.

Step 4

Thread the vertical cables (1/4" DIA) through the guide tubes on the poles. Fasten the vertical cables the same way as the horizontal cables, with a 1/2" x 9" turnbuckle at the top of the pole (See Detail A) and a heavy-duty shackle at the bottom of the pole (See Detail D).

Step 5

Once all of the cables have been mounted on the poles, use the turnbuckles to tension the horizontal and vertical cables. Be sure not to overtighten turnbuckles and cause the poles to deflect.

TITLE: Cable Attachment	DWG NO: ID-00110
	SHEET 1 OF 1

NOTE: To ensure desired netting tension, stretch nets on the ground prior to installation.

Your net will arrive 2 feet longer and 1 foot taller than the actual field dimensions and only will be poly rope bound on the left and top perimeters.

Setting Net Position

Step 1

Zip tie the net and sewn border rope to the vertical cable starting from the top left corner (A) and working downward (B).

Step 2

Zip tie the net and sewn border rope to the horizontal cable starting from the top left corner (A) and working rightward to the next vertical cable (C).

Step 3

Zip tie the net to the vertical cable starting from the top right corner (C) and working downward (D).

Step 4

Stretch the net downward until taut. Zip tie the net to the horizontal cable starting from the bottom right corner (D) and working leftward (B). Zip tie around the full mesh square. Use the same row of mesh squares across the entire horizontal cable to keep the net square.

Step 5

Repeat Steps 1-4 for each panel of the net.

Step 6

Trim the excess netting on all sides, staying in the same row of net mesh squares throughout. Leave a full net mesh square around the perimeter.

Securing the Net

Step 1

Starting at the bottom, weave 1/4" poly rope adjacent and parallel to the bottom horizontal cable through every 3-4 net mesh squares, staying in the same row of net mesh squares throughout. Repeat this process for each vertical cable.

Step 2

Lash the net with 1/8" twine around the entire net perimeter, including woven 1/4" poly rope and all vertical cables. Wrap around the poly rope and galvanized cable, tying a clinch knot every 3-5 squares. See installation video:

www.sportsfield.com/products/ball-safety-netting-systems/tension-netting-systems#instructional-videos

Step 3

Zip tie one "Do Not Stand Next to Netting" sign on each panel of the net. Orient the sign properly to face spectators.

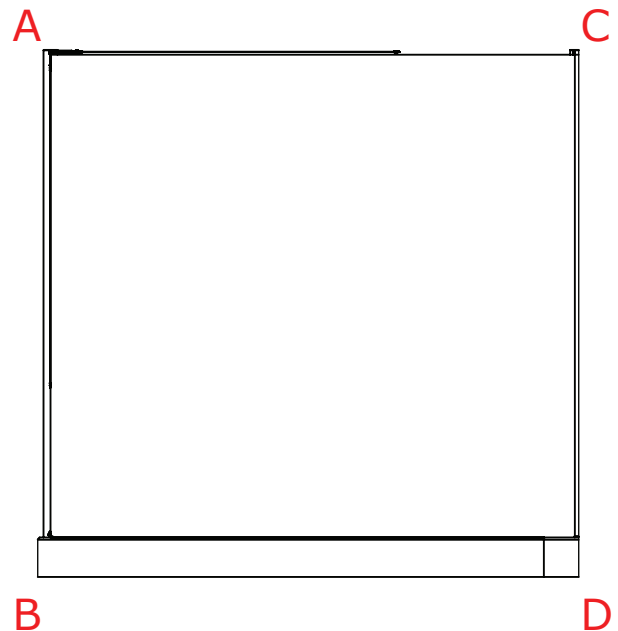

Failure to follow the recommended netting installation will void the manufacturer's warranty.

TITLE:

Netting Attachment

DWG NO:

ID-00254

SHEET 1 OF 1

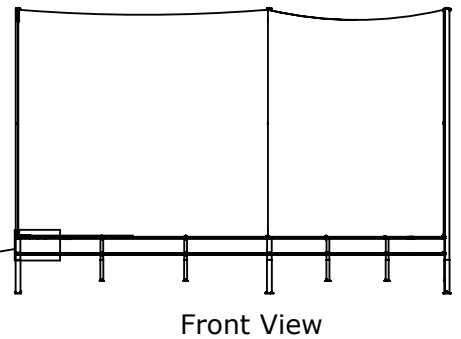
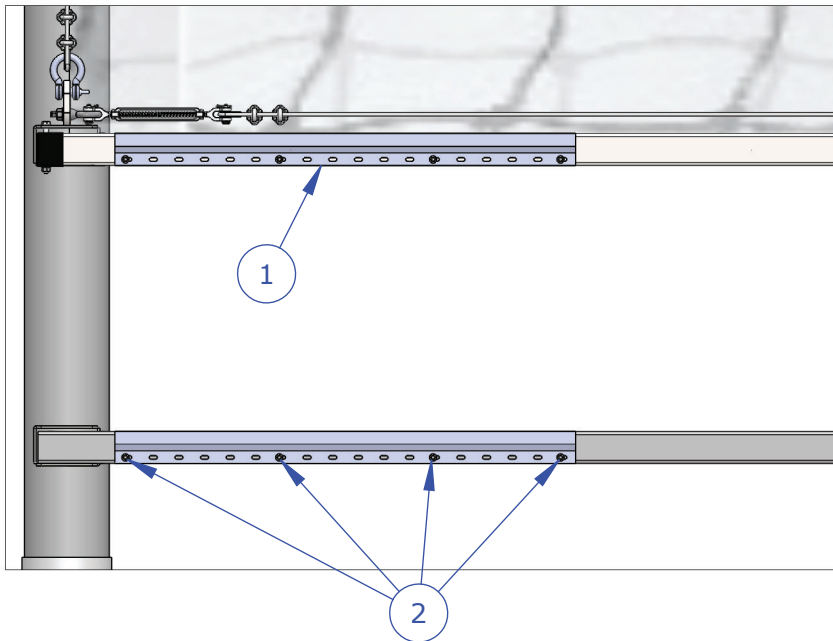
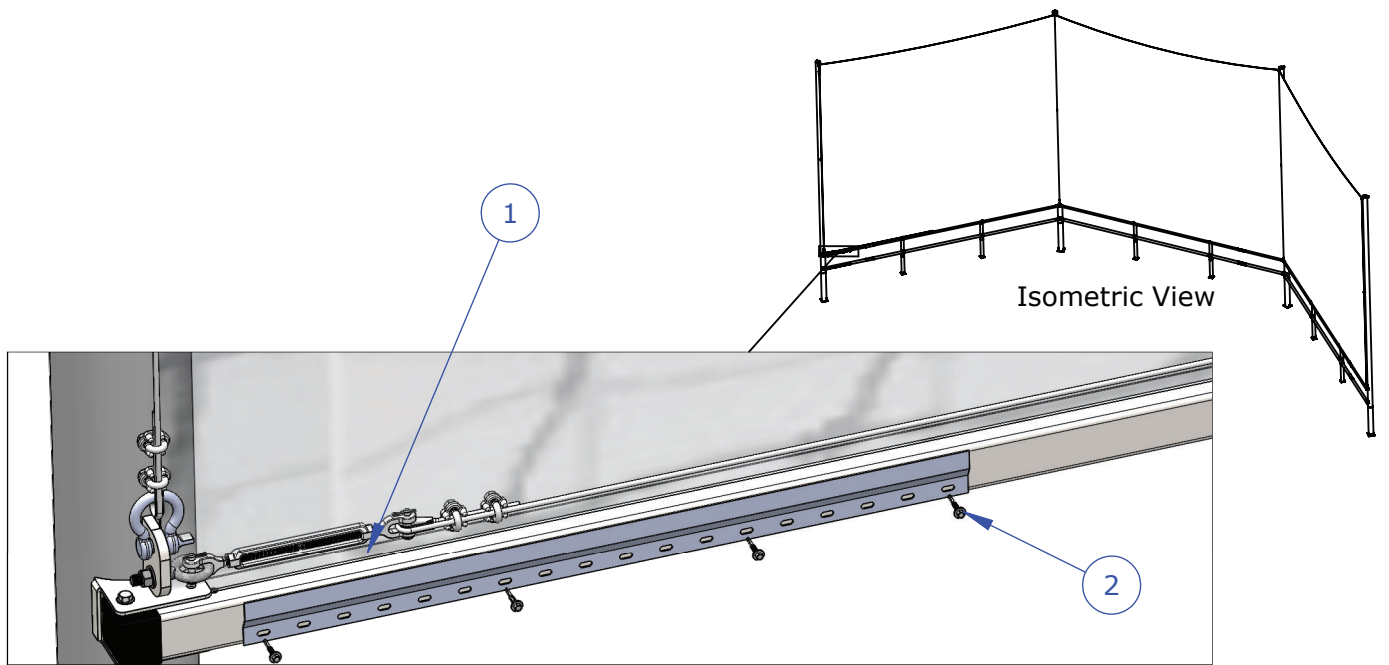

Attach Z-Clips to both the upper and lower rails at the approximate center of each pad using shown connection hardware. Orient Z-Clip as shown, such that the bottom edge sits flush with the bottom edge of the rail. Four self-drilling screws are required per Z-Clip.

There should be two Z-Clips per pad, one per rail. Z-Clips may need to be cut to fit non-standard size pads. Standard pads are 4' wide.

ITEM NO.	SAP Part Number	DESCRIPTION
1	540-MET-0016	Z-Clip; 36" w/ 18 Holes; Aluminum
2	105-SCREWS-0007	#12 x 1-1/2" Hex Head Self Drilling Carbon Screws w/Oxyseal Coating and head painted BLACK (06)
TITLE: Z-Clip Attachment		DWG NO: ID-00111
		SHEET 1 OF 1

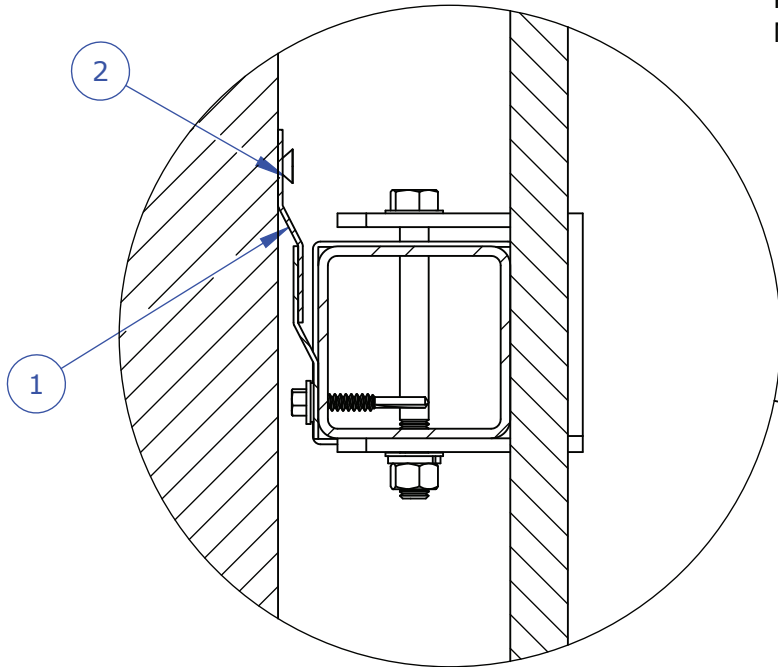
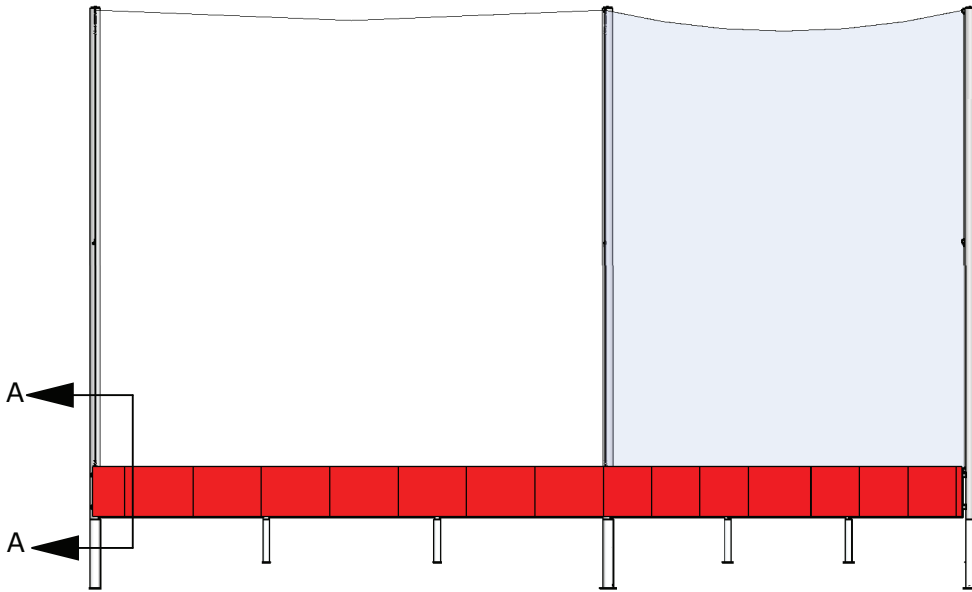

Pad and Backer Board
May be Raised Max 3"

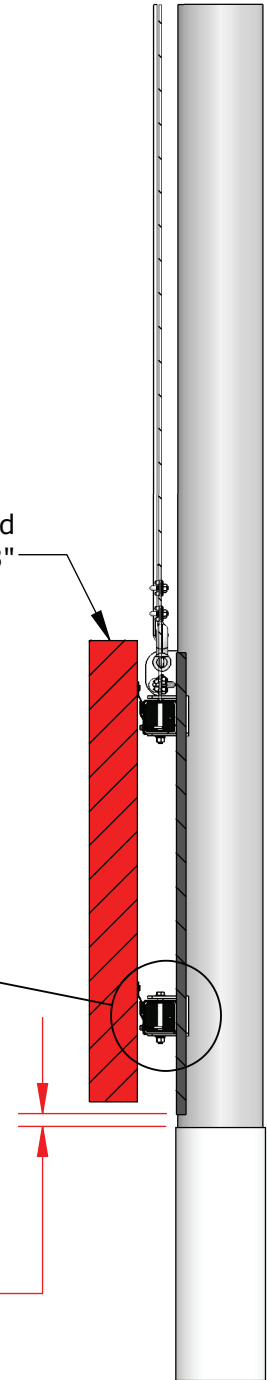

1" Standard Reveal
from Finish Grade,
May Vary by
Project Requirements

SECTION A-A

Attach pad panels using second Z-Clip, which will sit flush with the previously installed Z-Clip that is attached to the rail. Z-Clips need to be attached to the back of the pad at desired reveal height. Please note Z-Clip orientation. Four self-drilling screws are required per Z-Clip. Use this connection at each Z-Clip location.

ITEM NO.	SAP Part Number	DESCRIPTION
1	540-MET-0016	Z-Clip; 36" w/ 18 Holes; Aluminum
2	104-SCREWS-0045	#12 x 1" L, Pan Head Marine Wood Screw, Phillips Drive, SS

TITLE: Pad Attachment	DWG NO: ID-00157
	SHEET 1 OF 1

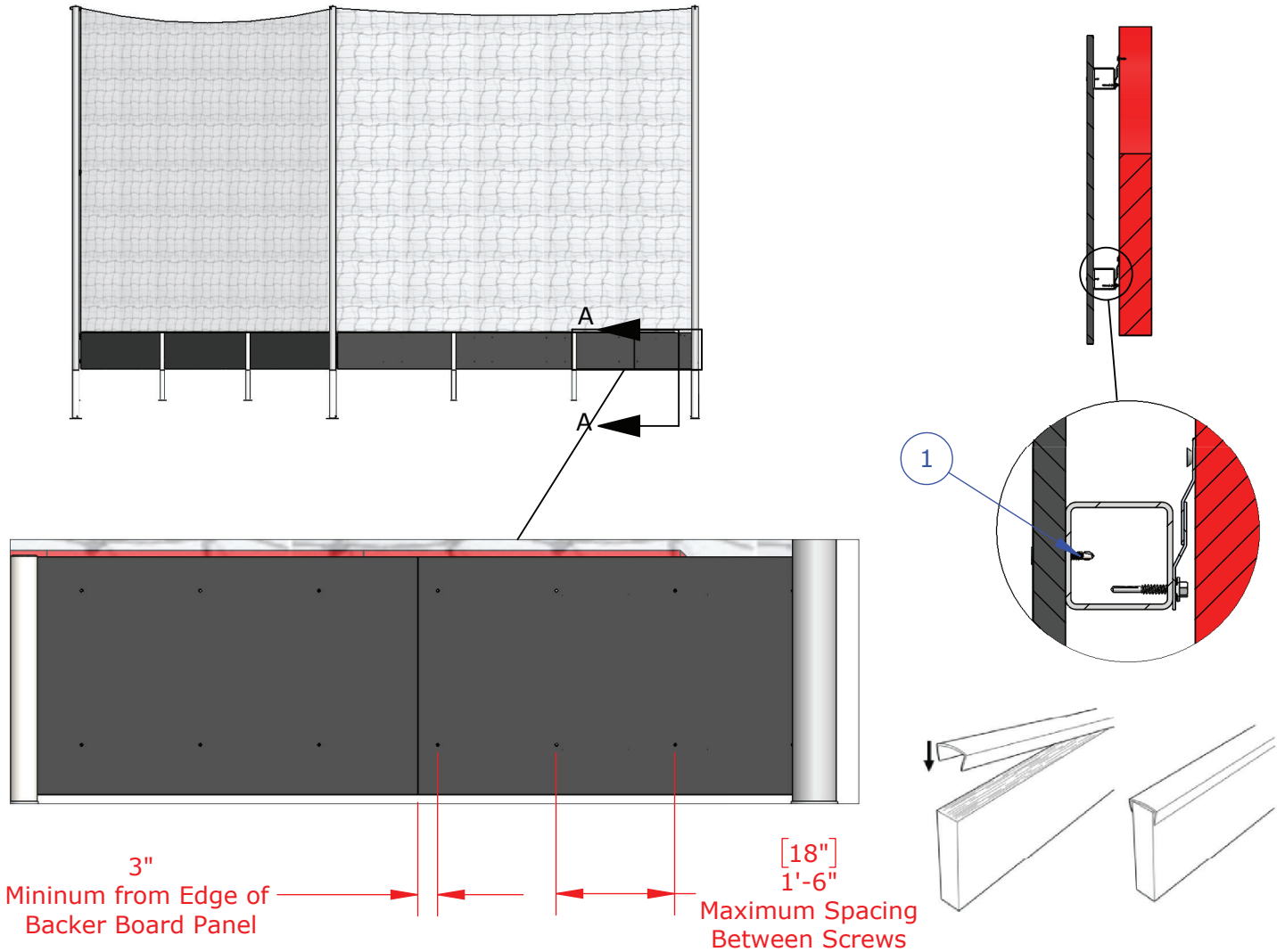

The top edge of the backer board panels should be flush with the tops of the intermediate poles. The backer board panels should be orientated with the high gloss finished side of the boards facing away from the field. Install backer board panels flush with inside to inside of poles. Fasten backer board panels to rail structure using shown connection hardware. Space screws a maximum of 18" apart and 3" minimum from edge of backer board panel.

Standard bottom reveal is 1", but may vary with project requirements. Backer board panels may be raised maximum 3". Field cuts and adjustments will be required. Touch-up paint is provided and should be used to paint any field cut edges (minimum of two coats) and over the heads of the screws.

Install supplied tapered, self-locking black PVC top cap channel over the top edge of the backer board panels as shown in the above diagram. Apply a 1" long bead of supplied adhesive every 12" to 18" to the inside of the black PVC top cap channel. Do not apply a full bead of adhesive to prevent overflow.

ITEM NO.	SAP Part Number	DESCRIPTION
1	105-SCREWS-0008	#10-24 x 1-7/16", Flat Head, Phillips Drive, Self-Drilling Gray Spex finish, Wood-to-Metal Screw
TITLE: Backer Board Panel Attachment		DWG NO: ID-00109 SHEET 1 OF 1