

Step 1

Remove the access frame covers. Unlock and remove the padlocks from the lockable hex-nut assemblies.

Step 2

Use the notched end of the GPR handle to loosen and lower the lockable hex-nut assemblies.

Caution: Both safety locking assemblies must be laying flat to prevent interference during the rotation process.

Caution: Heed all warning labels during operation

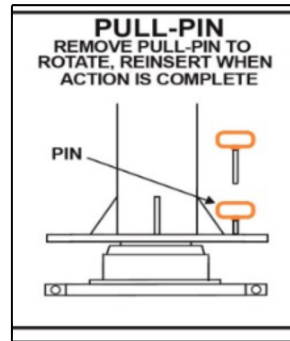
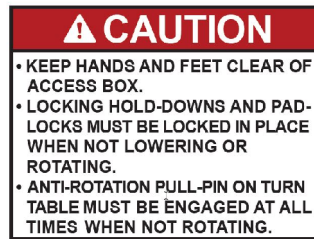
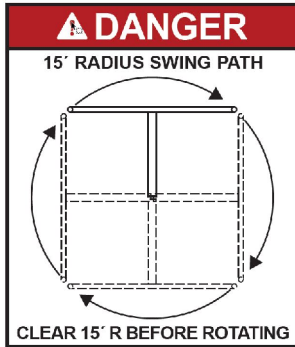

Step 3

Pull the anti-rotation locking pull pin. Using the GPR handle applied at the base of the gusset, Rotate 180° into the desired position. Replace pull pin.

Step 4

Re-engage both lockable hex-nut assemblies by using the notched end of the handle to tighten.

Step 5

Secure the padlocks and replace the access frame covers.

Caution: The goal should never be left unattended without the lockable hex-nut assemblies securely in place.

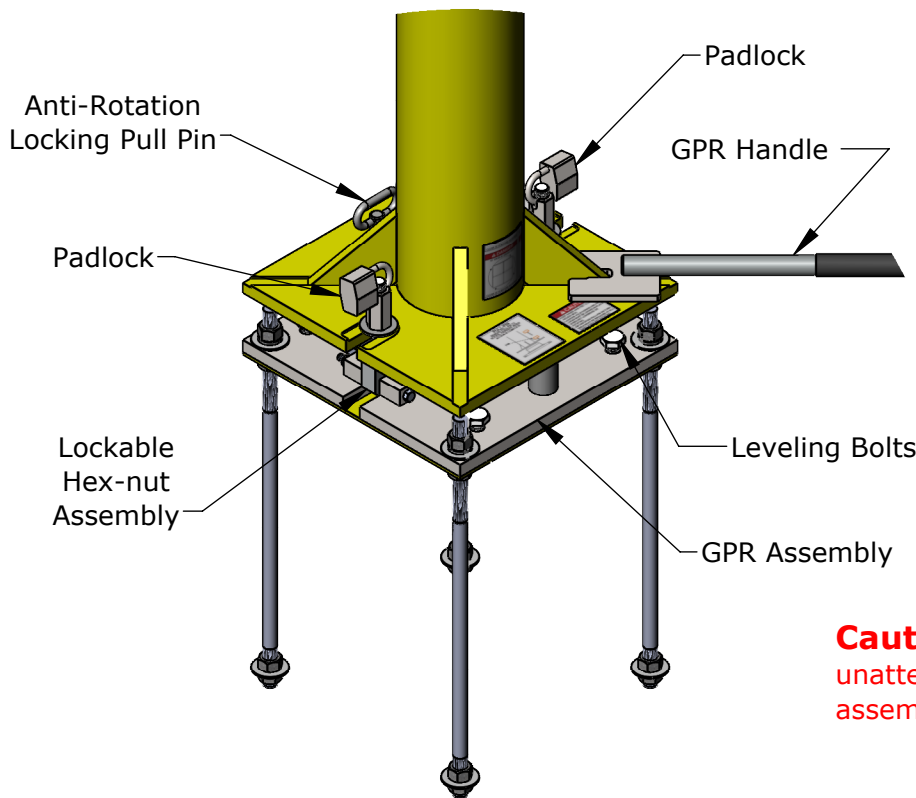

TITLE: Rotating Football Goal Post Rotating Operation

DWG NO:

ID-00027

SHEET 1 OF 1